

DATASHEET

Zhengi

SRFC015 • flexiiANT®



Features

- Antenna for 3G and 4G LTE applications including MIMO systems.
- GSM850, GSM900, DCS1800, PCS1900, WCDMA2100, LTE B7 (2500-2690MHz), LTE B30, B40 (2300-2400 MHz)
- 1.13mm diameter RF cable with I-PEX MHF connector
- Self-adhesive mounted
- Quick and simple integration minimizes design cycle
- Available in two standard cable lengths, 100mm and 200mm, other cable lengths are available.

1. Description

Zhengi is intended for use with 3G + 4G LTE applications. This antenna covers all 3G bands along with additional LTE bands (B7, B30, B38, B40, and B41). This product specification shows the performance of this antenna in all workable bands.

2. Applications

- Smart meters
- Femto / Pico base stations
- Telematics
- Remote monitoring
- Machine to Machine
- POS (Point of Sale) terminals

3. Part number

SRFC015-xxx



Part number	Cable length
SRFC015-100	100mm
SRFC015-150	150mm

Note. -xxx refers to cable

4. General data

Frequency	824-960MHz 1710-1990MHz 2110-2170MHz 2300-2400MHz 2500-2690MHz
Polarization	Linear
Operating temperature	-40°C to 85°C
Environmental condition test	ISO16750-4 5.1.1./5.1.2
Impedance	50 Ω
Weight	<0.5g
Antenna type	FPC Self-adhesive 3M 468MP
Dimensions (Antenna)	80.0 x 20.0 x 0.15 (mm)
Connection	I-PEX MHF1 (20278-112R-13)

5. RF characteristics

Frequency	824 – 960 MHz	1710 – 1990 MHz	2110 – 2170 MHz
Peak gain	0.50dBi	4.00dBi	3.50dBi
Average gain (Linear)	-2.50dBi	-1.50dBi	-2.50dBi
Average efficiency	>50%	>65%	>50%
Maximum return loss	-5.4dB	-6.0dB	-8.0dB
Maximum VSWR	3.30:1	2.90:1	2.10:1

Frequency	2300 – 2400 MHz	2500 – 2690 MHz
Peak gain	3.80dBi	5.00dBi
Average gain (Linear)	-2.50dBi	-1.50dBi
Average efficiency	>50%	>65%
Maximum return loss	-5.5dB	-6.0dB
Maximum VSWR	3.20:1	2.90:1

All data measured in a loaded condition adhered to a 1.6mm thick plastic carrier free space.

An RF choke was used to prevent cable radiation

6. RF performance

6.1. Return loss

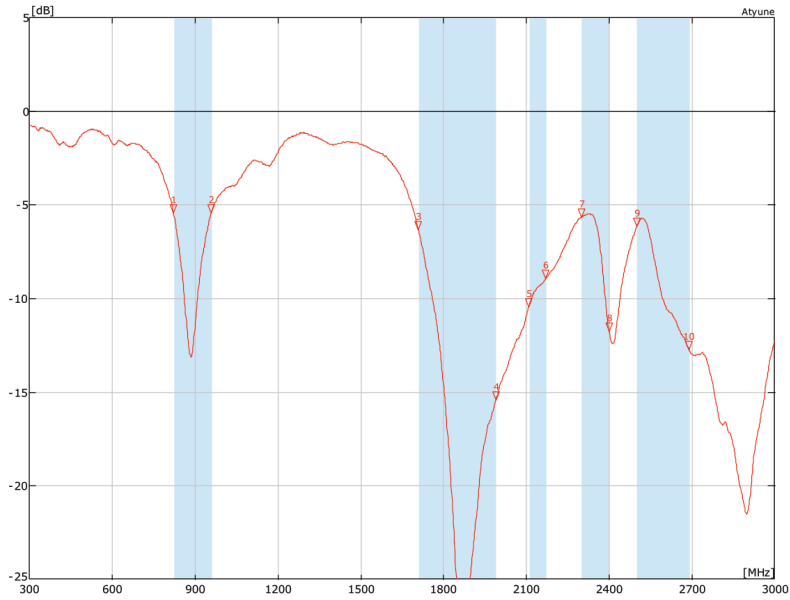

6.2. VSWR

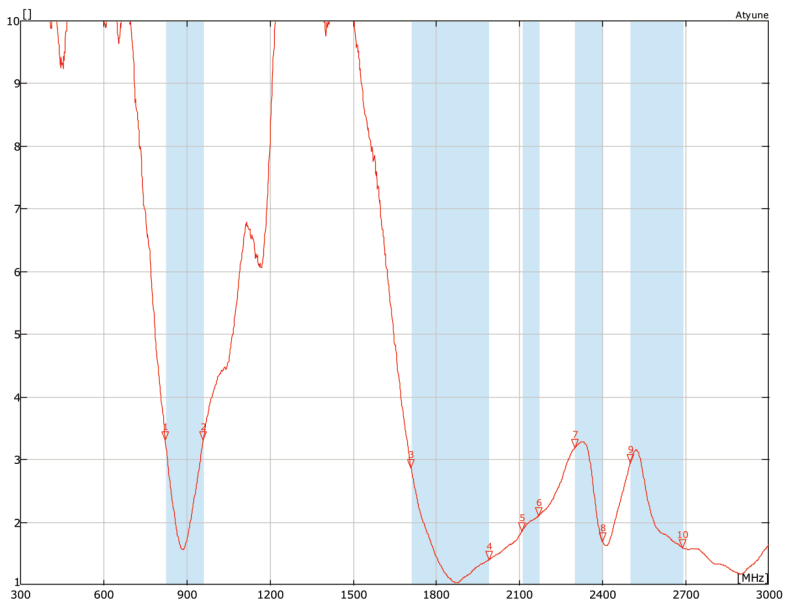

6.3. Efficiency

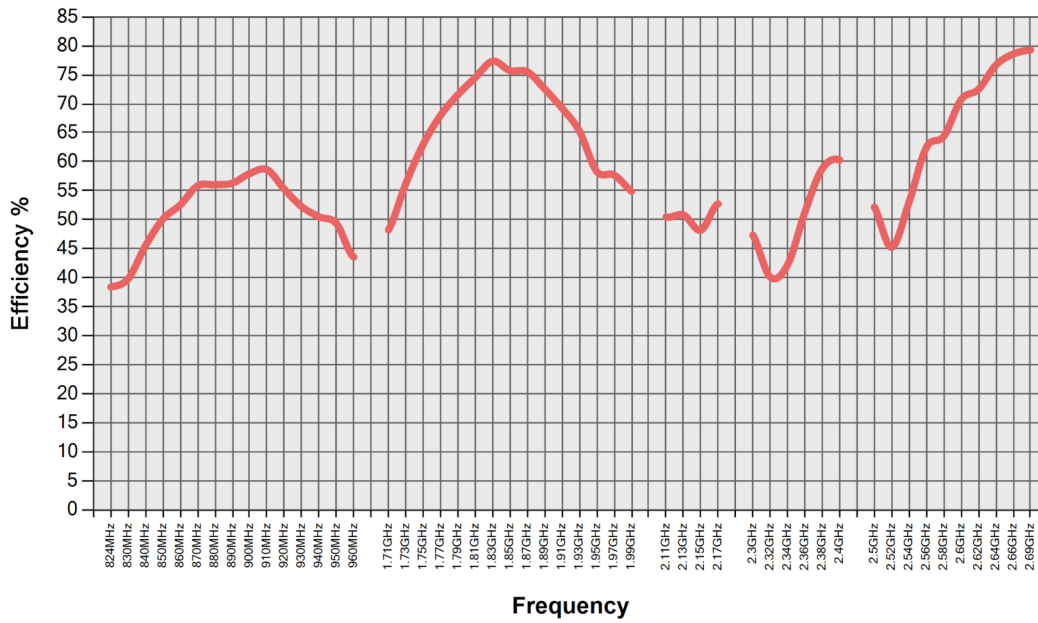

All data measured on SRFC015-100 in a loaded condition adhered to a plastic carrier in free space.

6.4. Antenna pattern

6.4.1. 824 MHz – 960 MHz

3D pattern at 890 MHz

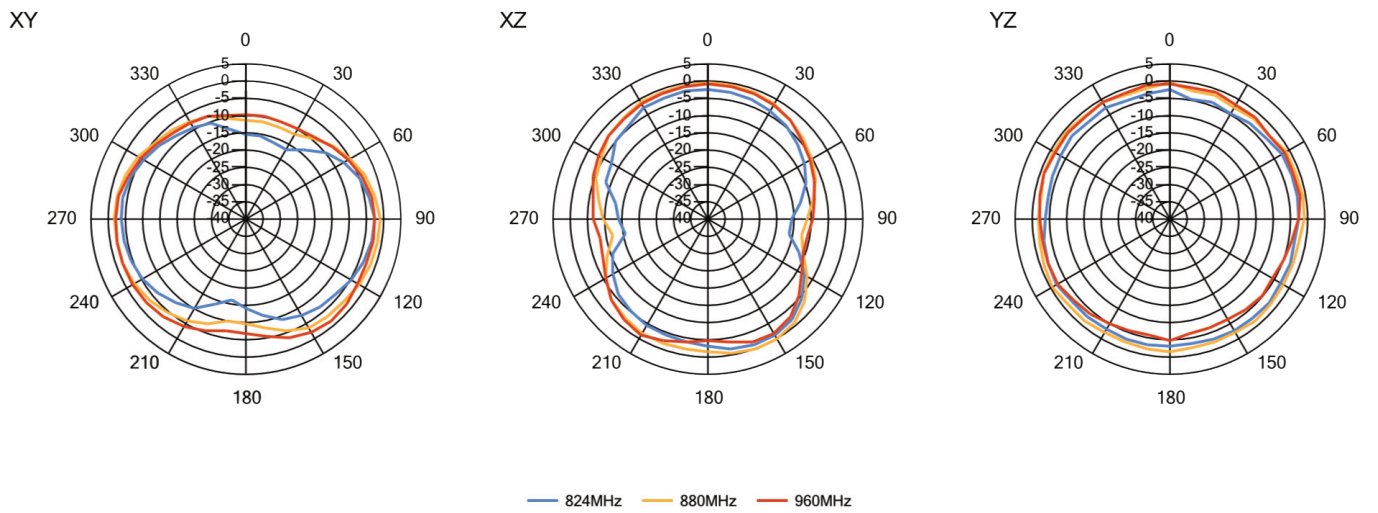
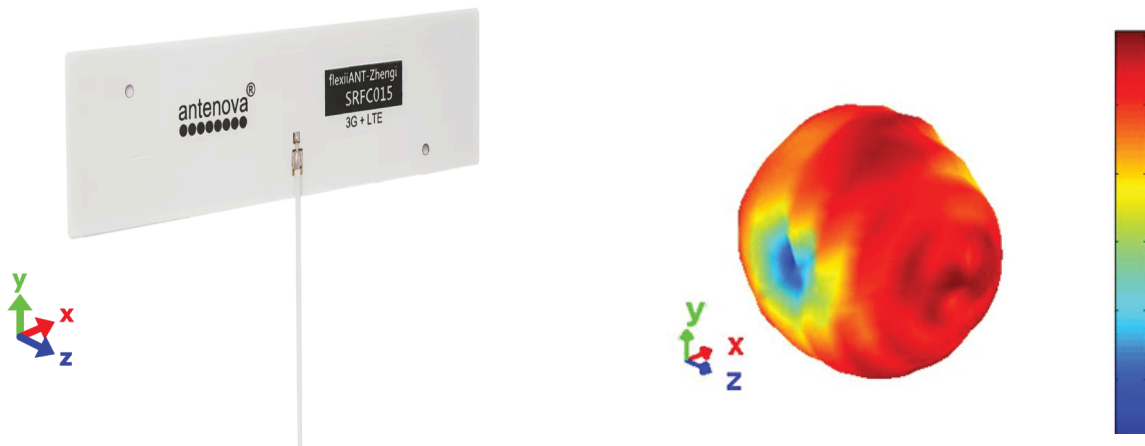

6.4.2. 1710 MHz – 2170 MHz

3D pattern at 1990 MHz



XY

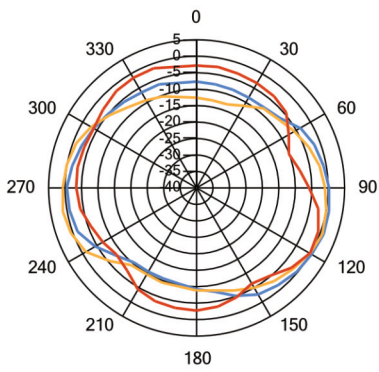

XZ

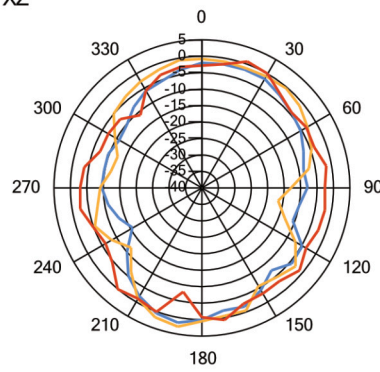

YZ

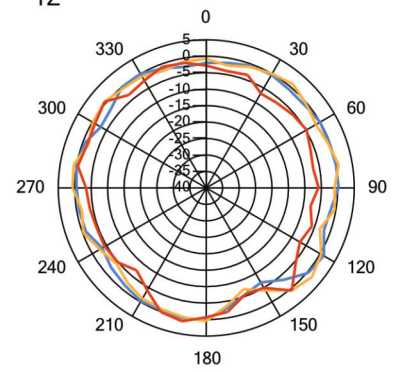

— 1.71GHz — 1.95GHz — 2.36GHz

6.4.3. 2300 MHz – 2400 MHz

3D pattern at 2350 MHz

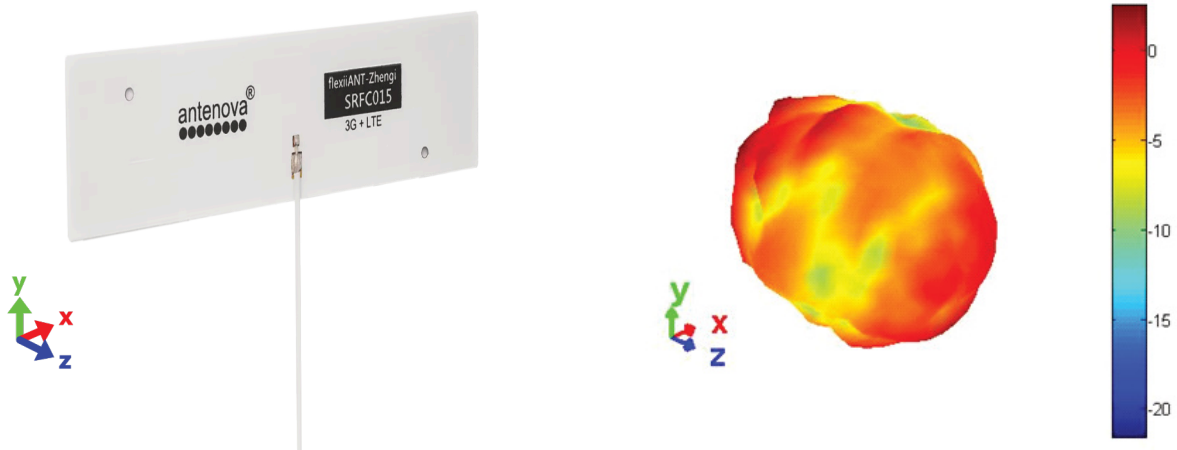

XY

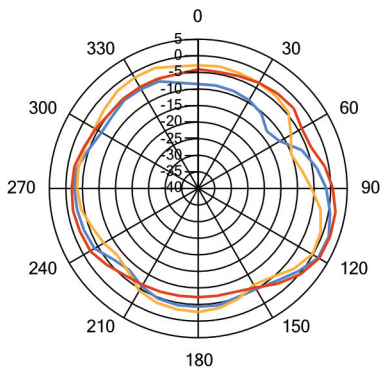

XZ

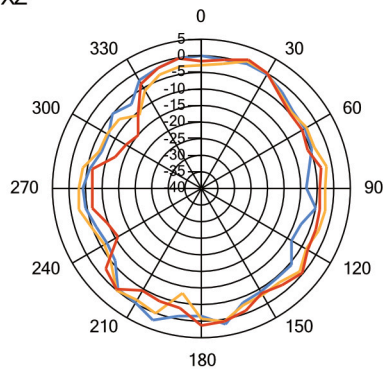

YZ

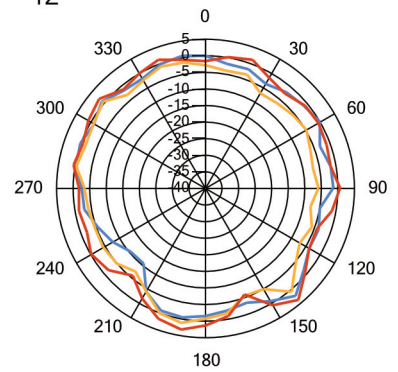

— 2.3GHz — 2.36GHz — 2.4GHz

6.4.4. 2500 MHz – 2690 MHz

3D pattern at 2600 MHz

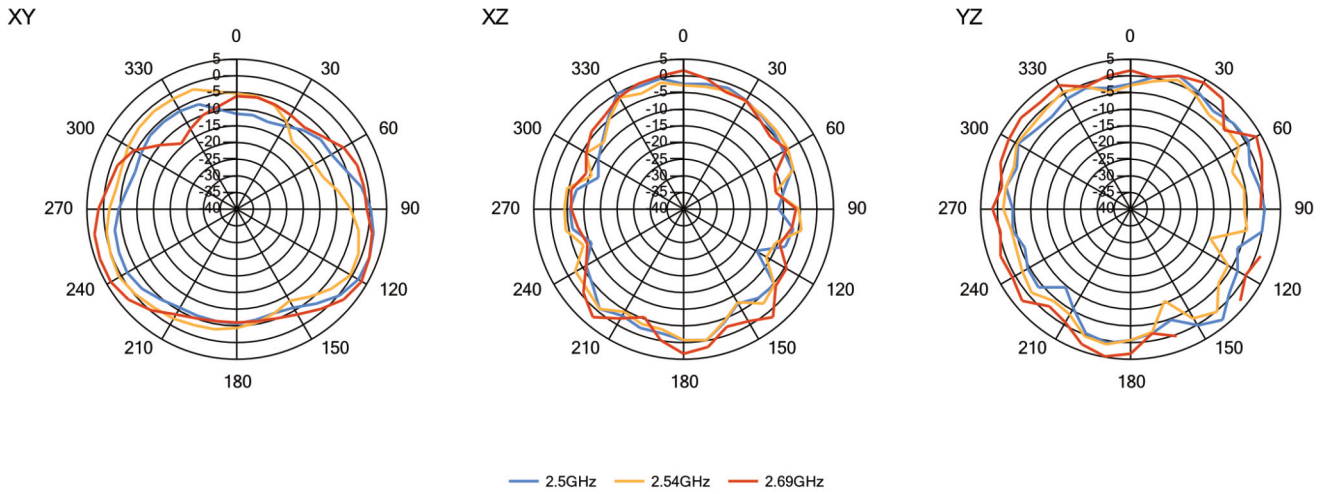
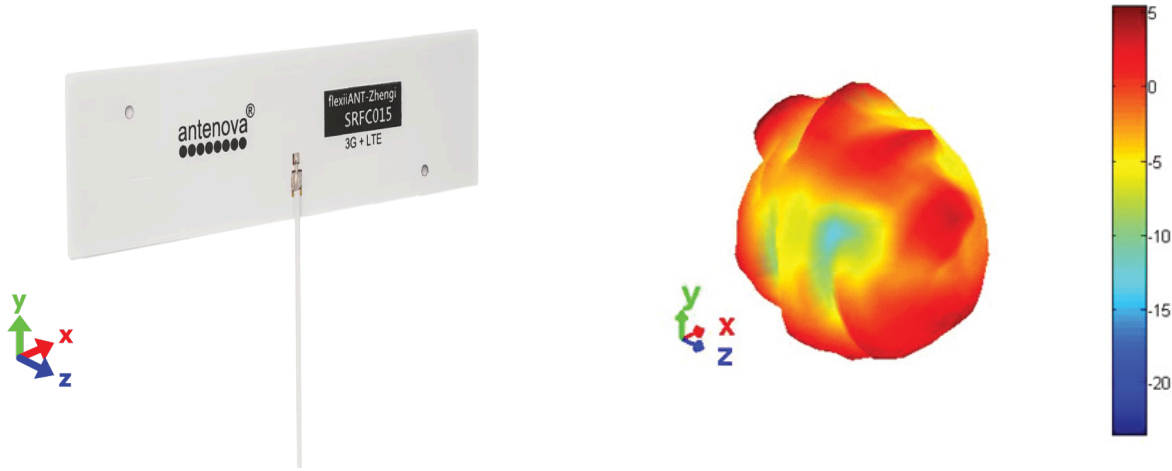

7. Antenna dimensions

7.1. Dimensions FPC section

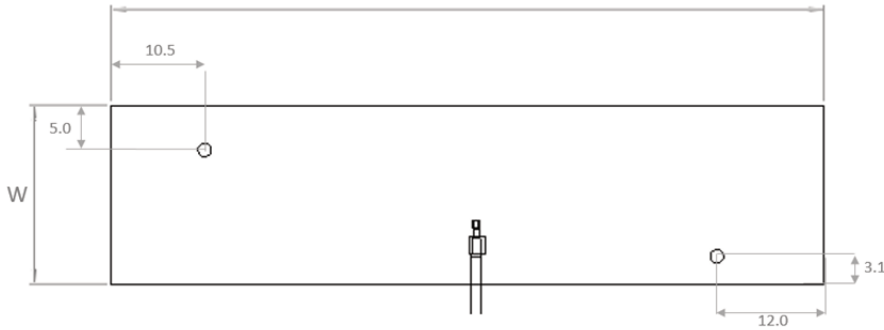

L	W	T
Length	Width	Thickness
80.0 ±0.2	20.0 ±0.2	0.15 (nominal)

All dimensions in (mm)

7.2. Dimensions assembled

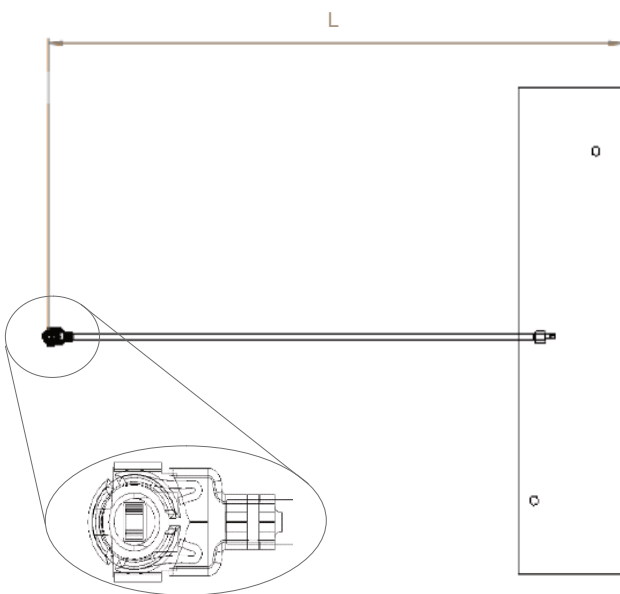

SRFC015-100	SRFC015-200
L	L
113 ±2.0 (mm)	213 ±2.0 (mm)

All dimensions in (mm)

7.3. I-PEX connector MHF1 (20278-112R-13)

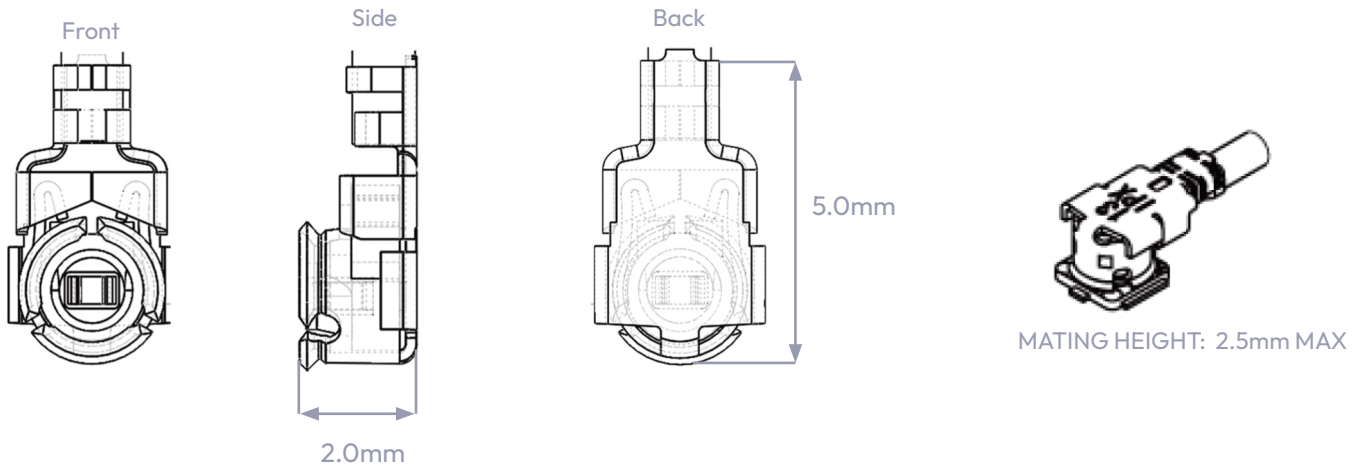

I-PEX	
Material	Copper alloy
Plating	Ag

All dimensions in (mm)

7.4. Assembly

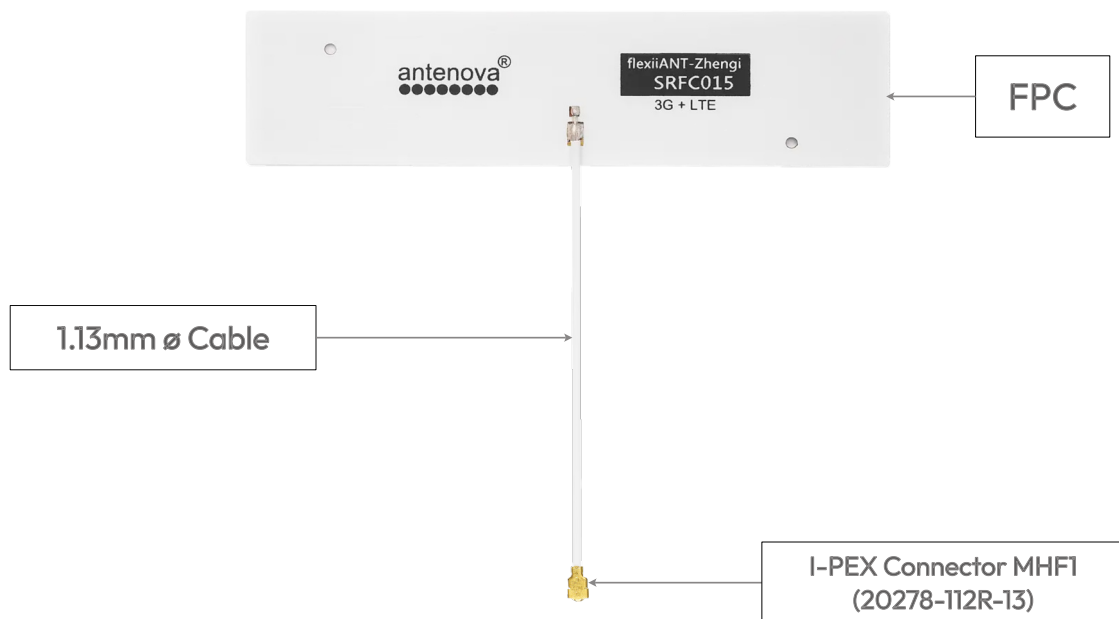

8. Electrical interface

8.1. Host interface

The host PCB requires the mating connector which is the I-PEX MHF (UFL) receptacle. The location should be close to the chip/modules pin for the RF. Any feed from this receptacle should be maintained at 50Ω impedance

8.2. Transmission line

- Must have a characteristic impedance of 50Ω.
- Length should be kept to a minimum.
- Is recommended to be a co-planar waveguide: log on to [Antenova.com](https://www.antenova.com) and try our [Transmission line calculator](#) to easily calculate the dimensions most suited to your requirements.
- Should have DC blocking capacitor (e.g. 220pF) placed in line to protect the RF front end.

9. Mechanical fixing

The antenna uses 3M 468MP adhesive on the reverse side of the FPC. The antenna has an easy access split line to peel off to reveal the adhesive side. It is designed for a one time fix to a clean smooth surface. The antenna is keyed with two 1mm locating holes for easy positioning.

FPC back side

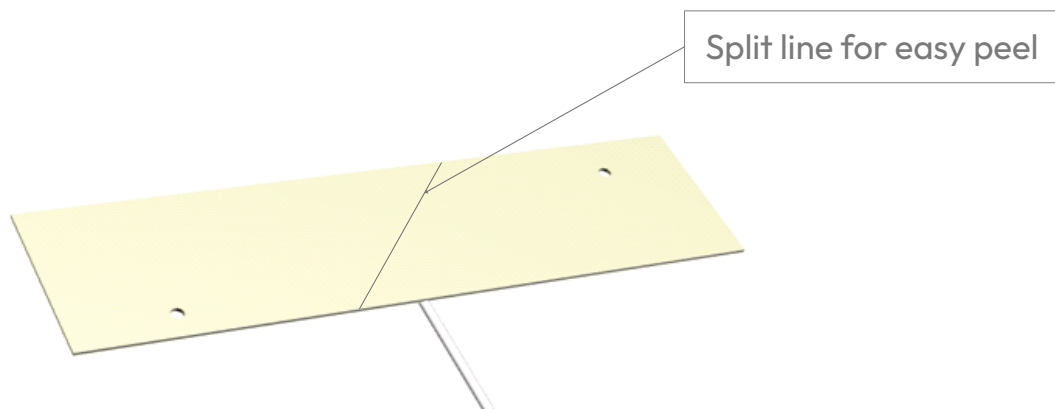

Split line for easy peel

10. Antenna integration guide

We recommend the following during the design phase to maximise antenna performance and minimize noise:

- Minimum 4 layer PCB
- Route signals and power internally where possible
- Flood all layers with ground
- Knit ground on all layers together with plenty of vias

Follow placement guidance carefully. Antenova provide technical support to help you with your design, and also provide design assistance on PTCRB certification. Register for an account on <https://ask.antenova.com/> to access technical support.

10.1. Antenna placement

For placing the FPC antenna within a device, the host PCB size is not a factor like with PCB mounted antennas. However placement still needs to follow some basic rules, as any antenna is sensitive to its environment.

Use the six spatial directions shown below as a guide. The antenna FPC section should ideally maintain a minimum of three directions free from obstructions to be able to operate effectively. The other directions will have obstacles in their paths - these directions still require a minimum clearance. These minimum clearances are further defined in this section. The plastic case is not included in this, only metal objects/components that will obstruct or come in close proximity to the antenna.

Six spatial directions relative to FPC

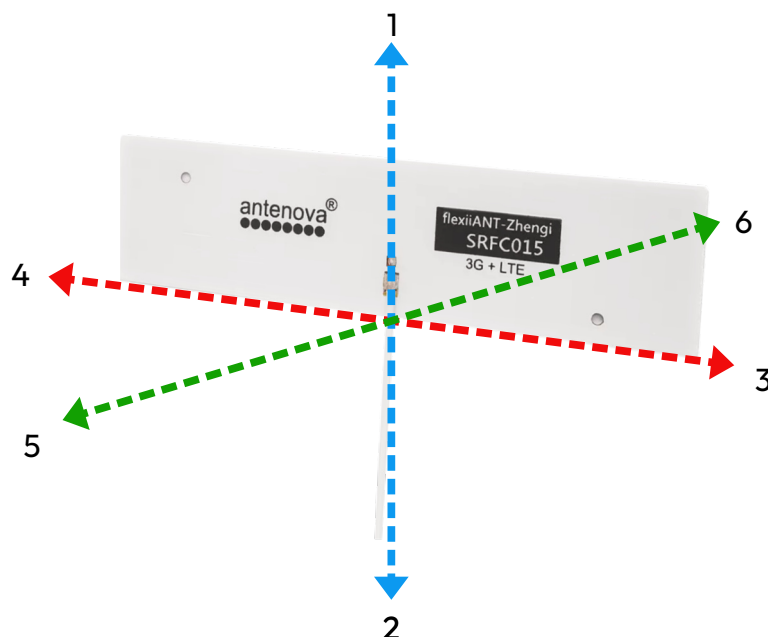

10.2. Orientation of FPC

The orientation of the FPC with respect to the host PCB should be defined depending on the unit. The proximity of the GND will have an influence on the antenna so the PCB location relative to the antenna should be considered.

The FPC will normally be placed in one of the three following options for orientation. In each option a distance (d) is the critical dimension to consider. The diagram below shows the minimum value of (d) for each. Other obstructions may increase this dimension.

Vertical mounted

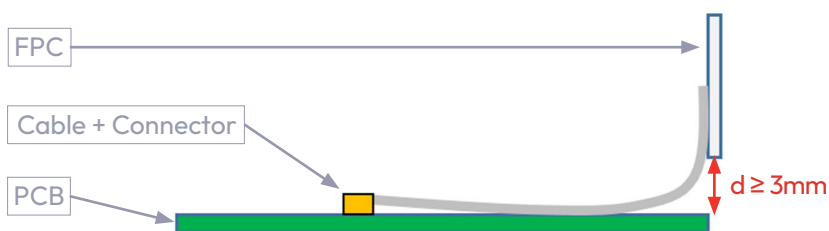

Co-planar to PCB

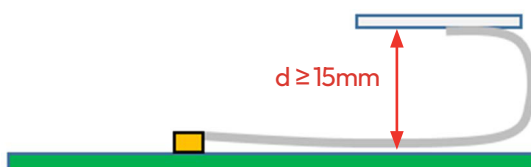

Planar to PCB (Same plane)



11. Hazardous material regulation conformance

The antenna has been tested to conform to RoHS and REACH requirements. A certificate of conformance is available from Antenova's website.

12. Packaging

The antennas are stored within a plastic bag of 100 pcs.

Single antenna per bag



100 units per bag (Labelled)

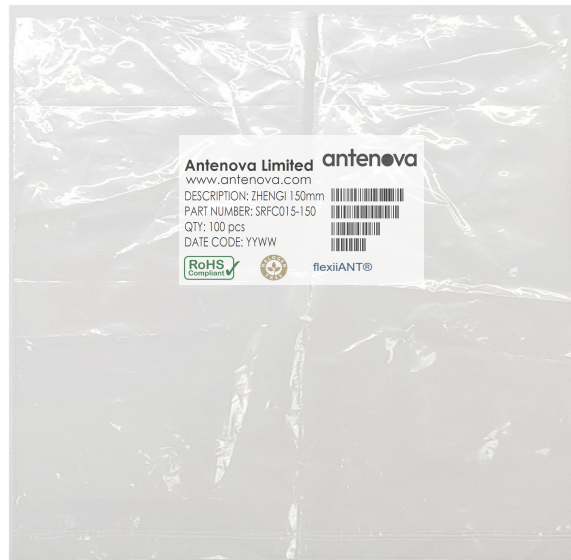





12.1. Optimal storage conditions

Temperature	-10°C to 40°C
Humidity	Less than 75% RH
Shelf life	18 Months
Storage place	Away from corrosive gas and direct sunlight
Packaging	Antennas should be stored in unopened sealed manufacturer’s plastic packaging.

Note: The shelf life of the antenna is 18 months, provided the bag of 100 pieces remains factory- sealed.

12.2. Label information

Antenova Limited **antenova**
 www.antenova.com
 DESCRIPTION: ZHENGI 150mm 
 PART NUMBER: SRFC015-150 
 QTY: 100 pcs 
 DATE CODE: YYWW 
  flexiiANT®

Antenova Limited **antenova**
 www.antenova.com
 DESCRIPTION: ZHENGI 150mm 
 PART NUMBER: SRFC015-150 
 QTY: 100 pcs 
 DATE CODE: YYWW 
  flexiiANT®

Quality statements

Antenova's products conform to REACH and RoHS legislation. For our statements regarding these and other quality standards, please see antenova.com.

Antenova reserves all rights to the contents of this document. Antenova gives no warranties based solely on the accuracy or completeness of the contents of this document and reserves the right to make changes to the specifications of the products described herein at any time and without notice.



Datasheet version

2.01 release 15th June 2026

Antenna design, integration and test resources

Product designers – the details contained in this datasheet will help you to complete your embedded antenna design. Please follow our technical advice carefully to obtain optimum antenna performance.

We aim to support our customers to create high performance wireless products. You will find a wealth of design resources, calculators and case studies to aid your design on our website.

Antenova's design laboratories are equipped with the latest antenna design tools and test chambers. We provide antenna design, test and technical integration services to help you complete your design and obtain the required certifications.

If you cannot find the antenna you require in our product range, please contact us to discuss creating a custom antenna to meet your exact requirements.

Share knowledge with RF Experts around the world

ask.antenova is a global forum for designers and engineers working with wireless technology

[Visit Ask.Antenova](#)

Visit antenova.com

Order antenna samples and evaluation boards, and read our antenna resources

[Visit antenova.com](http://antenova.com)

Request a volume quotation for antennas:

sales@antenova.com

+ 44 (0) 23 9400 1023

Global headquarters

**Antenova Ltd, 7 The Briars,
Waterberry Drive, Waterlooville,
Hampshire, PO7 7YH**